

XFP-ER

***XFP, 10GBase-ER, 10.3125 Gbps, 1550nm, DDM,
14dB, 40km***

INTRODUCTION

The XFP-ER is an optical transceiver module for high-speed, 10Gbit/s data transmission applications. The module is fully compliant to IEEE 802.3ae standard for Ethernet and the 10GFC Rev. 4 Fiber Channel standard, making it ideally suited for 10 GbE telecom, datacom and storage area network (SAN / NAS). Designed for distances of up to 40km the transceiver module comprises a DFB transmitter with an externally modulated laser (DFB-EA) and a receiver with a PIN photo diode. The transceiver operates within a wide temperature range of 0°C to +70°C and offers optimum heat dissipation and excellent electromagnetic shielding. The transceiver is fully compliant to the XFP MSA Rev. 4.5.

APPLICATIONS

- IEEE 802.3ae 10GBASE-SR 10.3125 Gb/s
- 10GFC
- Regional Networking

FEATURES

- Compatible with XFP MSA Rev. 4.5
- Compliant to IEEE 802.3ae 10GBASE-ER at 10.3125 Gbit/s
- Up to 40 km transmission on 9/125 μm SMF G.652
- 14 dB link budget
- Hot pluggable 30 pin connector
- 1550 nm laser (EML)
- Duplex LC-connector interface
- Compliant with the EU RoHS 6 Environmental Requirements
- operating temperature 0°C to 70°C

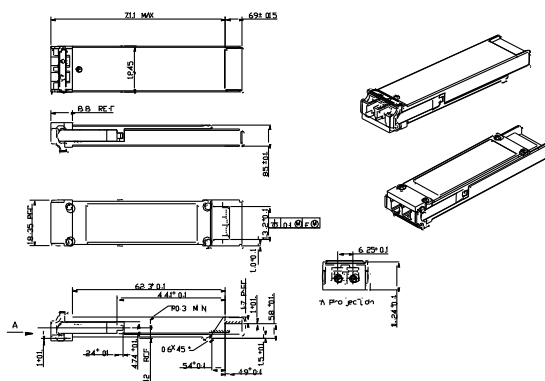

Specification subject to change without notice.

LASER SAFETY

This optical transceiver is a Class 1M laser product. It complies with IEC-60825 and FDA 21 CFR 1040.10 and 1040.11. The transceiver must be operated within the specified temperature and voltage limits. The optical ports of the module need to be terminated with an optical connector or with a dust plug.

Ordering Information

Part no:	Description/Application
XFP-ER	XFP, 10GBase-ER, 10.3125 Gbps, 1550nm, DDM, 14dB, 40km, 800ps/nm

Optical Parameters

Part no. Parameter	Wavelength [nm]	Opt. Output Power [dBm]	Opt. Receiver Sensitivity [dBm]	Power Budget[dB]
XFP-ER	1550	-1 to +2	-15 to -3	14 dB

Specification subject to change without notice.